



1.5 MHz, 1000mA Synchronous Buck Converter

DESCRIPTION

The GP5307 is a high efficiency 1.5MHz constant frequency, slope compensated current mode PWM step-down converter. The device integrates a main switch and a synchronous rectifier for high efficiency without an external Schottky diode. It is ideally suited for single Li-ion battery powered portable equipments. The GP5307 is capable to supply 1000mA of load current from a 2.5V to 5.5V input voltage. The low output voltage can be regulated as low as 0.6V. The GP5307 can also run at 100% duty cycle for low dropout operation, extending battery life in portable system. Idle mode operation at light loads provides very low output ripple voltage for noise sensitive applications.

The GP5307 is available in a space saving SOT23-5 package, and is available in fixed output voltage of 1.2V, 1.5V, 1.8V and adjustable version.

FEATURES

- Very High Efficiency: Up to 96%
- 1.5MHz Constant Switching Frequency
- 1000mA Output Current at $V_{IN} = 3V$
- 2.5V to 5.5V Input Voltage Range
- Output Voltage as Low as 0.6V
- Integrated Main switch and Synchronous rectifier. No Schottky Diode Required
- 100% Duty Cycle in Low Dropout operation
- Low Quiescent Current: 270 μ A at active mode
- Slope Compensated Current Mode Control for Excellent Line and Load Transient Response
- <1 μ A supply current at Shutdown mode
- Thermal Fault Protection
- Short Circuit Protection
- Tiny SOT23-5 package

APPLICATIONS

- Cellular and Smart Phones
- DSC and DVC
- Wireless and DSL Modems
- MP3 / MP4 Players
- PDAs and Portable Instruments
- Microprocessors and DSP Core Supplies

Typical Application

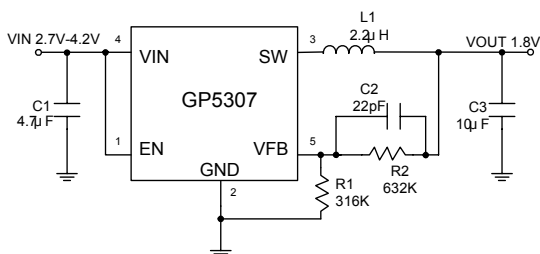
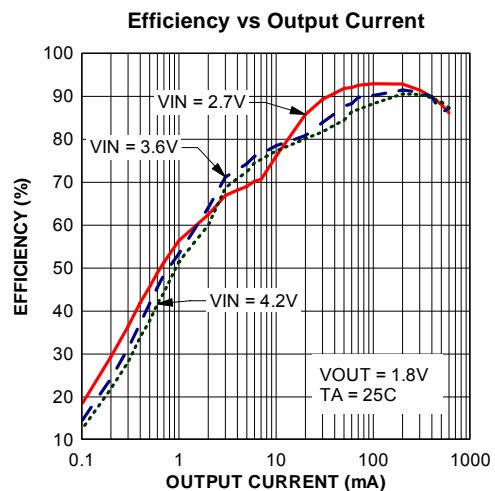

Figure 1. Basic Application Circuit with GP5307 adjustable version, $V_{out} = 1.8V$



Absolute Maximum Rating ^(Note 1)

Input Supply Voltage -0.3V to +6V
 RUN, V_{FB} Voltages -0.3V to V_{IN}+0.3V
 SW, V_{out} Voltages -0.3V to V_{IN}+0.3V
 Peak SW Sink and Source Current..... 1.5A

Operating Temperature Range ...-40°C to +85°C
 Junction Temperature ^(Note2) +125°C
 Storage Temperature Range.....-65°C to +150°C
 Lead Temperature (Soldering, 10s) +300°C

Package/Order Information

Adjustable Output Version:

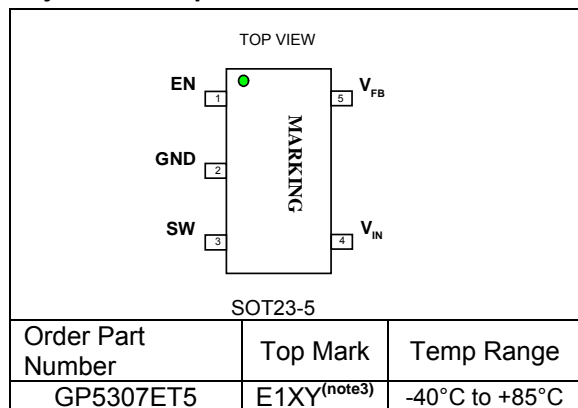

Fixed Output Versions:

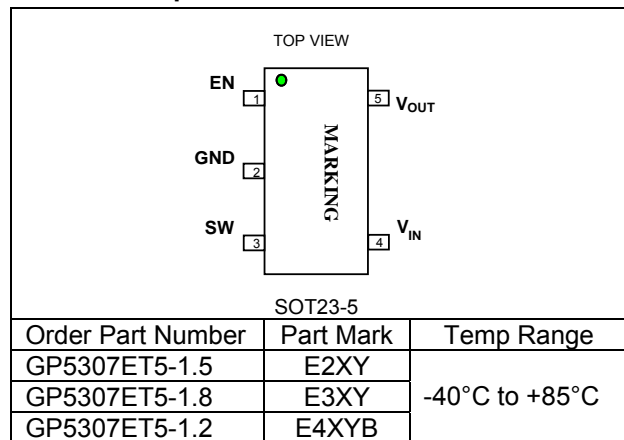

Order quantity: minimum 3,000ea/Tape Reel

Thermal Resistance ^(Note 4):

Package	Θ_{JA}	Θ_{JC}
SOT23-5	250°C/W	110°C/W

Note 1: Absolute Maximum Ratings are those values beyond which the life of a device may be impaired.

Note 2: T_J is calculated from the ambient temperature T_A and power dissipation P_D according to the following formula:

$$T_J = T_A + P_D \times \Theta_{JA}$$

Note 3: XY = Manufacturing Date Code

Note 4: Thermal Resistance is specified with approximately 1 square of 1 oz copper.

Note5: GPS Pb-free plus anneal products employ with molding compounds, die attach material and and 100% matte tin plate termination finish which are Rohs compliant and compatible with both SnPb and Pb-free soldering operations.

Caution: this device is sensitive to electrostatic discharge follow proper integrated circuit handling procedures.

Electrical Characteristics (Note 5)

($V_{IN}=V_{EN}= 3.6V$, $T_A = 25^{\circ}C$, Test Circuit Figure 1, unless otherwise specified.)

Parameter	Conditions	MIN	TYP	MAX	unit
Input Voltage Range		2.50		5.50	V
Input DC Supply Current					
Active Mode	$V_{FB} = 0.5V$, $V_{EN} = 3.6V$		270	400	μA
Shutdown Mode	$V_{IN} = 4.2V$, $V_{EN} = 0V$		0.08	1.0	μA
Regulated Feedback Voltage	$T_A = +25^{\circ}C$	0.5880	0.60	0.6120	V
	$T_A = 0^{\circ}C \leq T_A \leq 85^{\circ}C$	0.5865	0.60	0.6135	V
	$T_A = -40^{\circ}C \leq T_A \leq 85^{\circ}C$	0.5850	0.60	0.6150	V
V_{FB} Input Bias Current	$V_{FB} = 0.65V$			± 30	nA
Reference Voltage Line Regulation	$V_{IN} = 2.5V$ to $5.5V$, $V_{OUT} = V_{FB}$ ($R2=0$)		0.11	0.40	%/V
Regulated Output Voltage	GP5307ET5-1.2, $-40^{\circ}C \leq T_A \leq 85^{\circ}C$	1.164	1.200	1.236	V
	GP5307ET5-1.5, $-40^{\circ}C \leq T_A \leq 85^{\circ}C$	1.455	1.500	1.545	V
	GP5307ET5-1.8, $-40^{\circ}C \leq T_A \leq 85^{\circ}C$	1.746	1.800	1.854	V
Output Voltage Line Regulation	$V_{IN} = 2.5V$ to $5.5V$, $I_{OUT} = 10mA$		0.11	0.40	%/V
Output Voltage Load Regulation	I_{OUT} from 0 to 600mA		0.0015		%/mA
Maximum Output Current	$V_{IN} = 3.0V$	1000			mA
Oscillator Frequency	$V_{FB} = 0.6V$ or $V_{OUT} = 100\%$	1.2	1.5	1.8	MHz
$R_{DS(ON)}$ of N-CH MOSFET	$I_{SW} = -300mA$		0.20	0.45	Ω
$R_{DS(ON)}$ of P-CH MOSFET	$I_{SW} = 300mA$		0.30	0.50	Ω
Peak Inductor Current	$V_{IN} = 3V$, $V_{FB} = 0.5V$ or $V_{OUT} = 90\%$ Duty Cycle <35%		1.20		A
SW Leakage	$V_{EN} = 0V$, $V_{SW} = 0V$ or $5V$, $V_{IN} = 5V$		± 0.01	± 1	μA
Output over voltage lockout	$\Delta V_{OVL} = V_{OVL} - V_{FB}$		60		mV
EN Threshold	$-40^{\circ}C \leq T_A \leq 85^{\circ}C$	0.3	0.45	1.30	V
EN Leakage Current			± 0.1	± 1	μA

Note 5: 100% production test at $+25^{\circ}C$. Specifications over the temperature range are guaranteed by design and characterization.

Typical Performance Characteristics

(Test Figure 1 above unless otherwise specified)

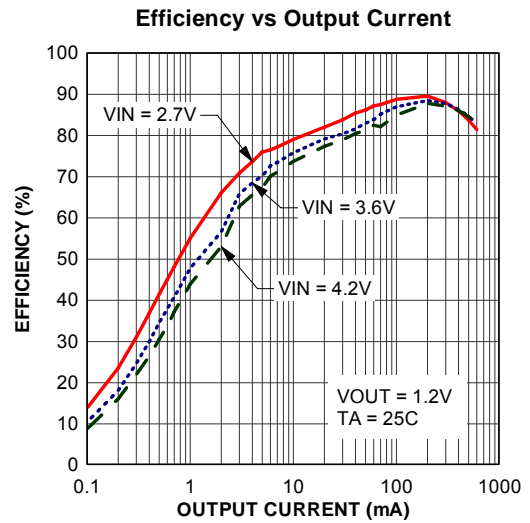
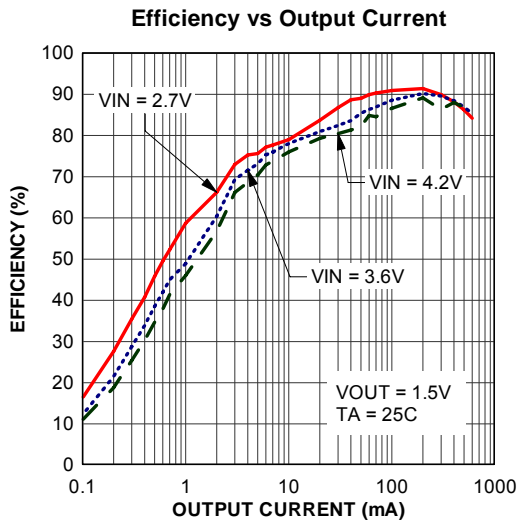
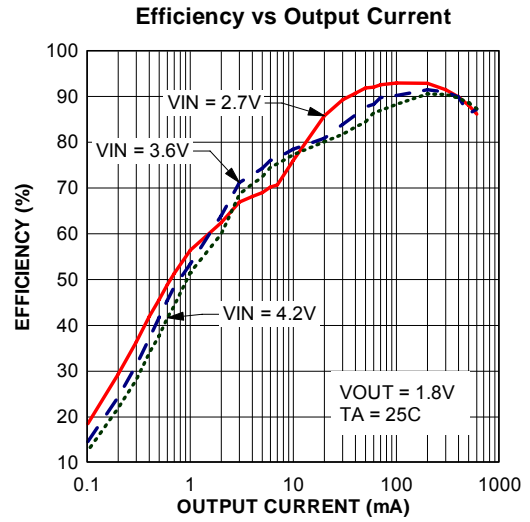
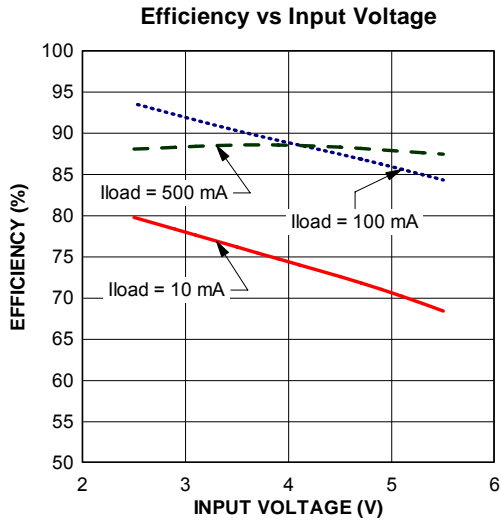

Efficiency vs Output Current

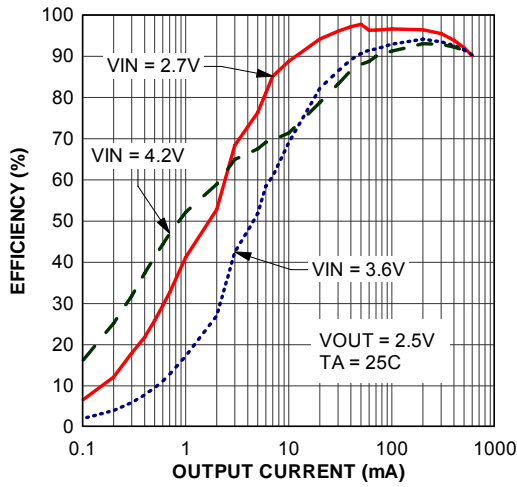

Efficiency vs Load Current

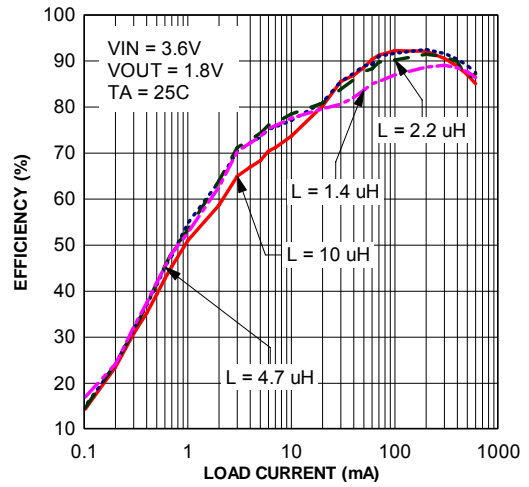

Efficiency vs Load Current

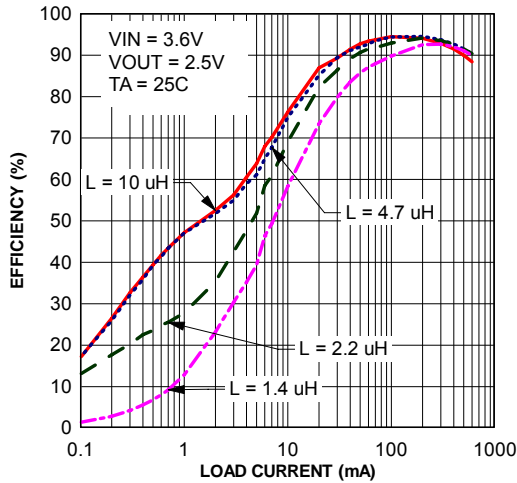

Output Voltage vs Load Current

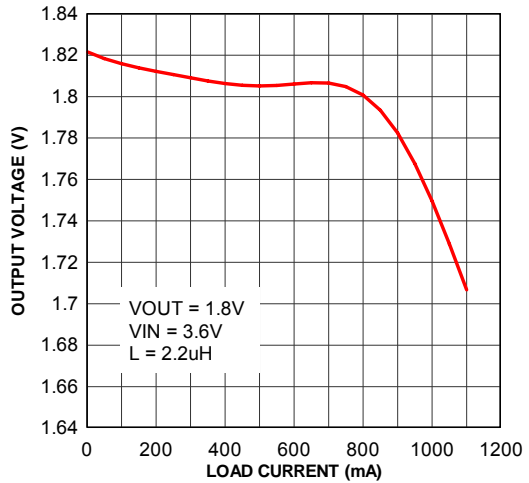

Frequency vs Input Voltage

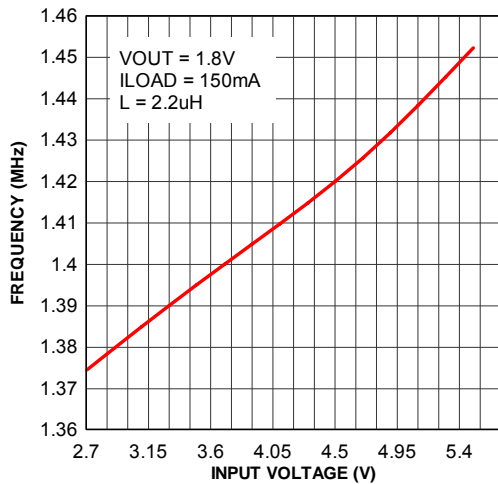

RDS(ON) vs Input Voltage

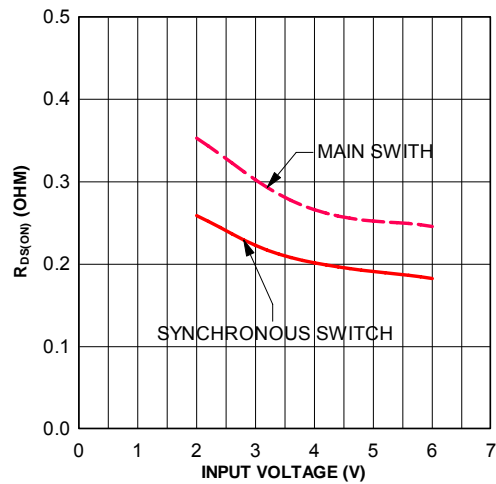

Reference Voltage vs Temperature

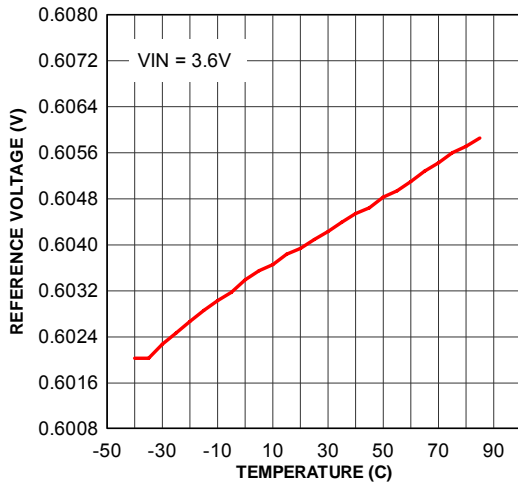

R_{DS(ON)} vs Temperature

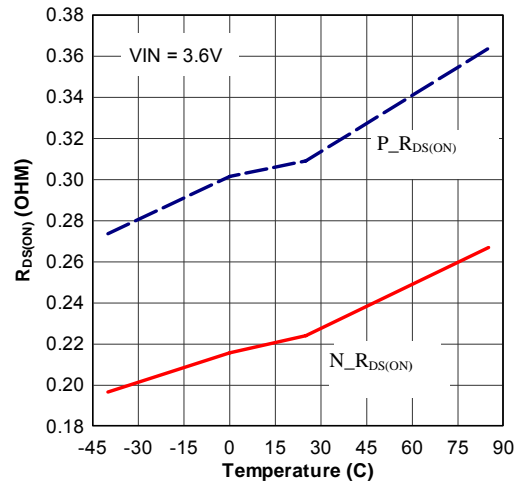

Input Voltage vs Input Current

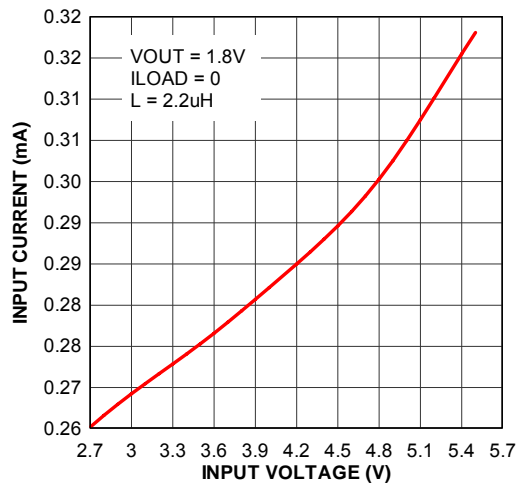

Frequency vs Temperature

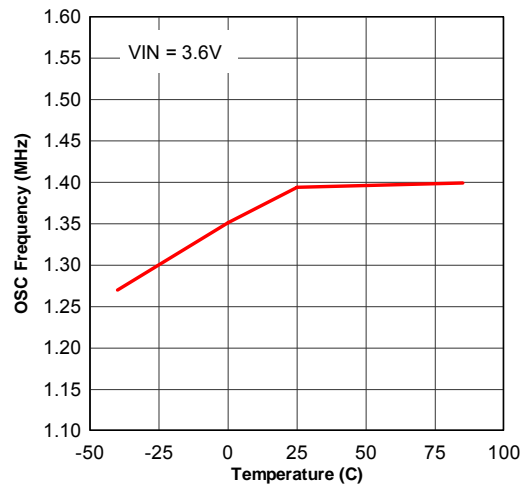

Supply Current vs Temperature

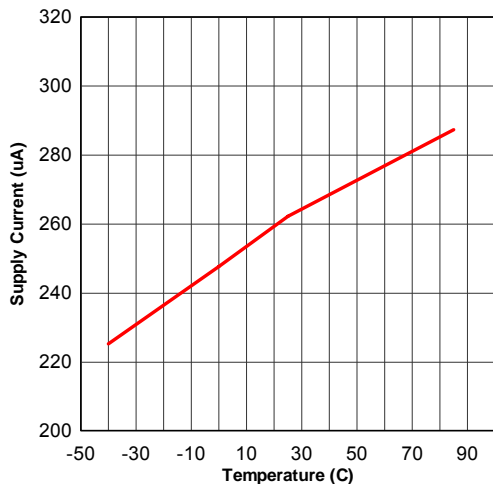

PWM Mode Load Transient Response

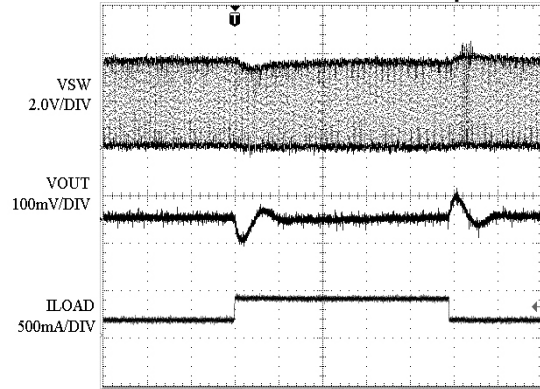

Iload = 100 mA TO 400 mA
 L=2.2uH, Cin=10uF, Cout=10uF, Vin=3.6V, Vout=1.8V

Load Transient Response
 Idle Mode to PWM Mode

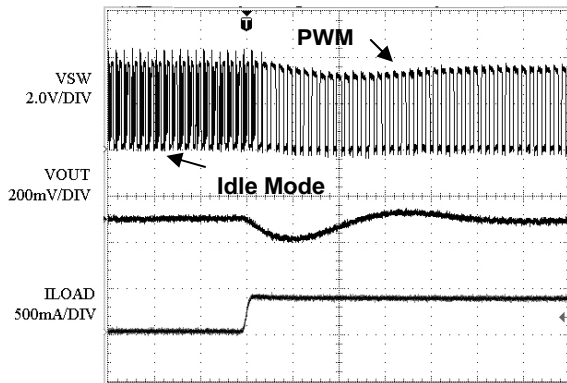

Iload = 28 mA TO 400 mA
 L=2.2uH, Cin=10uF, Cout=10uF, Vin=3.6V, Vout=1.8V

Pin Description

PIN	NAME	FUNCTION
1	EN	Chip enable control input. Input EN above 1.5V to turn on the chip. Drive EN below 0.3V to turn Chip off. In shutdown mode, all functions are disabled drawing <math><1\mu\text{A}</math> supply current. Do not leave EN pin floating.
2	GND	Ground connection
3	SW	Power Switch Output. It is the Switch node connection to Inductor. This pin connects to the drains of the internal P-CH and N-CH MOSFET switches.
4	IN	Power supply Input Pin. Must be closely decoupled to GND, Pin 2, with a 2.2 μF or greater ceramic capacitor.
5	FB / Vout	V _{FB} (GP5307): Feedback Input Pin. Connect FB to the center point of the R1, R2 resistor divider connect to the V _{OUT} . The feedback threshold voltage is 0.6V. V _{OUT} (GP5307-1.2/GP5307-1.5/GP5307-1.8). Output Voltage Feedback Pin. An internal resistive divider(R1, R2) divides the output voltage down for comparison to the internal set reference voltage.

Functional Block Diagram

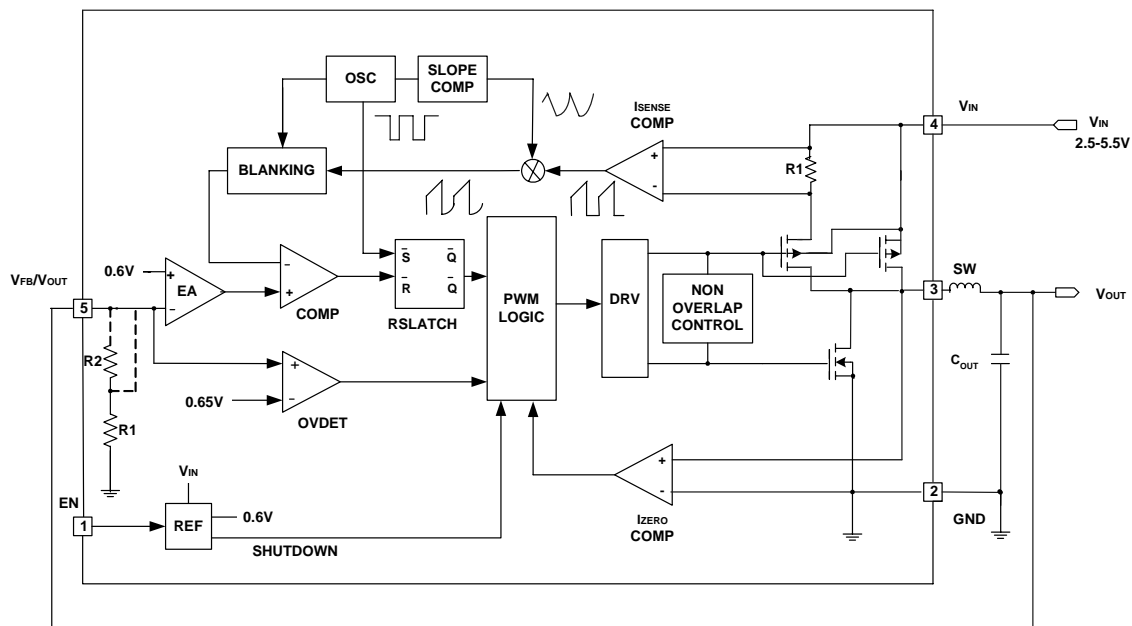

Figure 2. GP5307 Block Diagram

Operation

GP5307 is a monolithic switching mode Step-Down DC-DC converter. Its built in internal MOSFETs achieve high efficiency and can generate very low output voltage by using internal reference at 0.6V. It operates at a fixed switching frequency, and uses the slope compensated current mode architecture. This Step-Down DC-DC Converter supplies 1000mA output current at $V_{IN} = 3V$ with input voltage range from 2.5V to 5.5V.

Current Mode PWM Control

Slope compensated current mode PWM control provides stable switching and cycle-by-cycle current limit for excellent load and line responses and protection of the internal main switch (P-Ch MOSFET) and synchronous rectifier (N-CH MOSFET). During normal operation, the internal P-Ch MOSFET is turned on for a certain time to ramp the inductor current at each rising edge of the internal oscillator, and switched off when the peak inductor current is above the error voltage. The current comparator, I_{COMP} , limits the peak inductor current. When the main switch is off, the synchronous rectifier will be turned on immediately and stay on until either the inductor current starts to reverse, as indicated by the current reversal comparator, I_{ZERO} , or the beginning of the next clock cycle. The OVDET comparator controls output transient overshoots by turning the main switch off and keeping it off until the fault is no longer present.

Idle Mode Operation

At very light loads, the GP5307 automatically enters Idle Mode. In Idle Mode, the inductor current may reach zero or reverse on each pulse. The PWM control loop will automatically reduce pulses to maintain output regulation. The bottom MOSFET is turned off by the current reversal comparator, I_{ZERO} , and the switch voltage will ring. This is discontinuous mode operation, and is normal behavior for the switching regulator.

Dropout Operation

When the input voltage decreases toward the value of the output voltage, the GP5307 allows

the main switch to remain on for more than one switching cycle and increases the duty cycle ^(Note6) until it reaches 100%. The output voltage then is the input voltage minus the voltage drop across the main switch and the inductor. At low input supply voltage, the $R_{DS(ON)}$ of the P-Channel MOSFET increases, and the efficiency of the converter decreases. Caution must be exercised to ensure the heat dissipated not to exceed the maximum junction temperature of the chip.

Note 6: The duty cycle D of a step-down converter is defined as:

$$D = T_{ON} \times f_{OSC} \times 100\% \approx \frac{V_{OUT}}{V_{IN}} \times 100\%$$

Where T_{ON} is the main switch on time and f_{OSC} is the oscillator frequency (1.5MHz).

Maximum Load Current

The GP5307 will operate with input supply voltage from 5.5V to as low as 2.5V, however, the maximum load current decreases at lower input due to large IR drop on the main switch and synchronous rectifier. The slope compensation signal reduces the peak inductor current as a function of the duty cycle to prevent sub-harmonic oscillations at duty cycles greater than 50%. Conversely the current limit increases as the duty cycle decreases.

Layout Guidance

When laying out the application PC board, the following suggestions should be taken to ensure proper operation of the GP5307. These items are also illustrated graphically in Figure 3.

1. The high current power traces, including the GND trace, the SW trace and the V_{IN} trace should be kept short, direct and wide.
2. The V_{FB} pin should be connected directly to the feedback resistor. The resistive divider $R1/R2$ must be connected between the (+) plate of $C3$ and ground.
3. Connect the (+) plate of $C1$ to the V_{IN} pin as closely as possible. This capacitor provides the AC current to internal power MOSFET.
4. Keep the (-) plates of $C1$ and $C3$ as close as possible.
5. Make the switching node, SW, away from the sensitive V_{FB} node as possible.

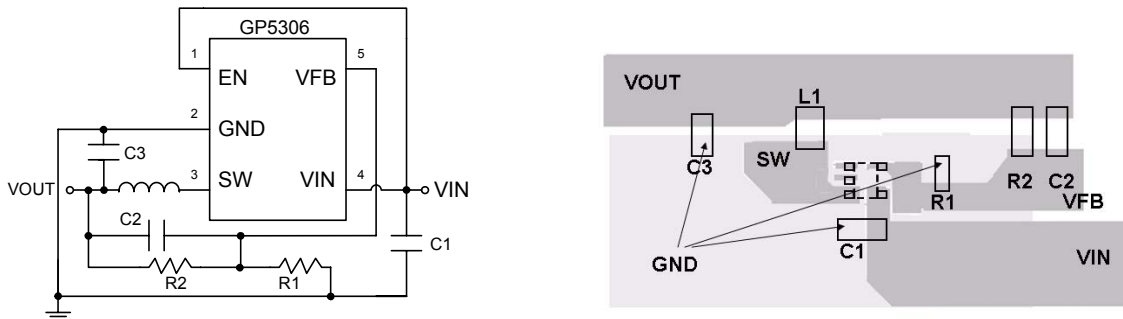

Figure 3. GP5307 Layout Example

APPLICATIONS INFORMATION

Figure 4 below shows the basic application circuit with GP5307 fixed output versions.

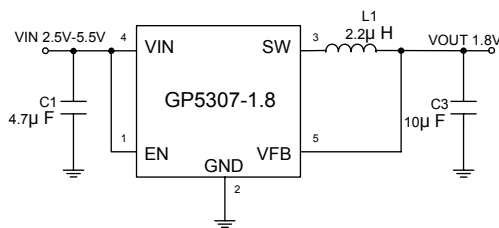

Figure 4. Basic Application Circuit with fixed output versions

Setting the Output Voltage

Figure 1 shows the basic application circuit with GP5307 adjustable output version. The external resistor sets the output voltage according to the following equation:

$$V_{OUT} = 0.6V \times \left(1 + \frac{R2}{R1}\right)$$

R1= 300kΩ for all outputs; R2= 300kΩ for V_{OUT}=1.2V, R2=450kΩ for V_{OUT}=1.5V, R2=600kΩ for V_{OUT} =1.8V, and R2 = 950kΩ for V_{OUT} =2.5V.

Inductor Selection

For most designs, the GP5307 operates with inductors of 1µH to 4.7µH. Low inductance values are physically smaller ,however, when require faster switching, it results in some efficiency loss. The inductor value can be calculated from the following equation:

$$L = \frac{V_{OUT} \times (V_{IN} - V_{OUT})}{V_{IN} \times \Delta I_L \times f_{OSC}}$$

Where ΔI_L is inductor Ripple Current. Large value inductors lower ripple current and small value inductors result in high ripple currents. Choose inductor ripple current approximately 35% of the minimum load current 1000mA, or $\Delta I_L = 350mA$.

For output voltages above 2.0V, when light-load efficiency is concerned, the minimum recommended inductor is 2.2µH. For optimum voltage-positioning load transients, choose an inductor with DC series resistance within the 50mΩ to 150mΩ range. For higher efficiency at heavy loads (above 200mA), or minimal load regulation (some transient may overshoot), the resistance should be kept less than 100mΩ. The DC current rating of the inductor should be at least equal to the maximum load current plus half the ripple current to prevent core saturation (1000mA+105mA). Table 1 lists some surface mount inductors for reference that meet target applications for the GP5307.

Part #	L (μH)	Max DCR (mΩ)	Rated D.C. Current (A)	Size WxLxH (mm)
Sumida CR43	1.4	56.2	2.52	4.5x4.0x3.5
	2.2	71.2	1.75	
	3.3	86.2	1.44	
	4.7	108.7	1.15	
Toko D312C	1.5	120	1.29	3.6x3.6x1.2
	2.2	140	1.14	
	3.3	180	0.98	
	4.7	240	0.79	
Sumida CDRH4D18	1.5	75	1.32	4.7x4.7x2.0
	2.2		1.04	
	3.3		0.84	
	4.7			

Table 1. Surface Mount Inductors for reference

Input Capacitor Selection

The input capacitor reduces the surge current drawn from the input and switching noise from the chip. The input capacitor impedance at the switching frequency shall be less than input

source impedance to prevent high frequency switching current passing to the input. A low ESR input capacitor sized for maximum RMS current must be used. Ceramic capacitors with X5R or X7R dielectrics are highly recommended because of their low ESR and small temperature coefficients. A 4.7μF ceramic capacitor for most applications should be sufficient.

Output Capacitor Selection

The output capacitor is required to keep the output voltage ripple small and to ensure regulation loop stability. The output capacitor must have low impedance at the switching frequency. Ceramic capacitors with X5R or X7R dielectrics are recommended due to their low ESR and high ripple current. The output ripple V_{OUT} is determined by following equation:

$$\Delta V_{OUT} \leq \frac{V_{OUT} \times (V_{IN} - V_{OUT})}{V_{IN} \times f_{OSC} \times L} \times \left(ESR + \frac{1}{8 \times f_{osc} \times C3} \right)$$

Package Description

SOT23-5 Package dimension

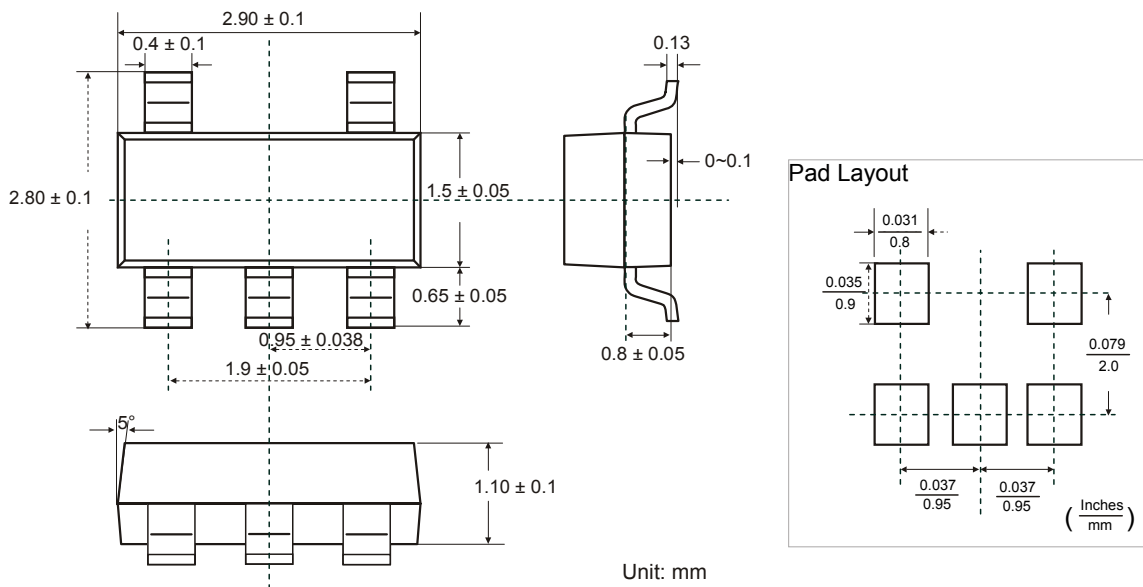

Note: Package outline exclusive of mold flash and metal burr.

IMPORTANT NOTICE

Green Power Semiconductor Inc. (GPS) reserves the right to make changes to its products specification without notice, and advises its customers to obtain the latest version of relevant information to verify, before placing orders, that the information being relied on is specification.

Some applications using integrated circuit products may involve potential risks of death, personal injury, or severe property or environmental damage. GPS integrated circuit products are not designed, intended, authorized, or warranted to be suitable for use in life-support applications, devices or systems or other critical applications. Use of GPS products in such applications is understood to be fully at the risk of the customer. In order to minimize risks associated with the customer's applications, the customer should provide adequate design and operating safeguards.

GPS assumes no liability to customer product design or application support. GPS warrants the performance of its products to the specifications applicable at the time of sale.